



# HOT WATER HEAT PUMPS LTD

Advancing Water Heat Pump Technology

SINCE 1980



**Econergy**<sup>®</sup>  
*The smarter way to heat water™*

## THD3500 HEAT PUMP WATER HEATER INSTALLATION GUIDE

FOR QUALIFIED PERSONNEL ONLY

14072022



**NOTE TO INSTALLERS:**

Installation must be completed by qualified and licensed Tradesmen to National Codes and in strict accordance with this manual.



**WARNING:**

A pre-made CAT -5/6 cable is required for installation of Econergy heat pumps

# CONTENTS

Location of the Water Heater Unit _____	4
Installation Design _____	5
Design to Avoid Cavitation _____	5
Distance from Hot Water Cylinder _____	5
Wetback Systems _____	5
Solar Water Heating Systems _____	6
Ring Main Management _____	6
Hot Water Cylinders _____	7
New Construction _____	8
Retrofit _____	8
Ordering Econergy Accessories _____	9
Installation _____	11
Typical Installation Detail _____	13
Installation Procedures _____	14
Mounting Systems _____	14
Pre-Wiring & Pre-Plumbing for Renovations & New Builds __	15
Piping Diagrams _____	16
Retrofit to Generic Single Inlet Hot Water Cylinder _____	16
Retrofit to Coopers Ready Mains PressureWater Cylinder _	17
Connection to Econergy HP Ready Hot Water Cylinder ____	18
Piping Instructions _____	19
Commissioning _____	21
Troubleshooting _____	23
Important Information _____	26
Field Wiring Diagram _____	27
Typical Heat Pump Ready Water Cylinder Product Specifications _	28
Econergy HP Series Water Heater Specifications _____	30
Company Information _____	31

# LOCATION OF THE WATER HEATER UNIT

Econergy® water heater units are designed to be installed outside, in the ceiling cavity (if one exists), under the house or in a garage, adjacent to the hot water cylinder (HWC). The Econergy® water heater should not be located within living areas as the unit produces cold air.

Location of the Econergy® water heater will be determined by a combination of factors including proximity to the hot water cylinder, proximity to bedrooms and whether there is usable space where the unit is going to be located.

For installation to existing homes, the unit should be installed with a maximum insulated pipe run of 9 metres.

For new homes, the layout should be designed so that the unit can be installed as close to the HWC as practical within the 9 metre maximum pipe run. The HWC can be installed inside or outside but as close to main points of use as possible.



**Econergy® Water Heaters must be installed in a well-ventilated space outside the living areas**



**The Econergy® Water Heater emits 52 dbA at 1.5 metres (THD3500) and should not be installed adjacent to bedrooms. Ensure that the unit is located so that noise will not affect the residents. The unit must be seismically restrained and located away from bedrooms to avoid noise breakthrough.**

# INSTALLATION DESIGN

## Design to Avoid Cavitation

The installation must be designed so that the unit will operate reliably and with no water flow issues due to cavitation.



**Cavitation of the circulating pump may occur when there is less than 50kPa pressure at the heat pump inlet. This can lead to a malfunction of the Econergy® water heater and MUST BE AVOIDED by ensuring adequate pressure at the system inlet.**

To ensure successful operation of the Econergy® water heater on open vent application where operating pressure is less than 50kPa (or 5m static head), a valve vented system should be used. This has the added benefit of increasing the pressure of supply in the house. The installer should be aware of and avoid adding a relief valve to an old HWC of questionable structural integrity since it could cause the HWC to fail.

## Distance from Hot Water Cylinder

The Econergy® water heater should be mounted as close as possible to the HWC to ensure best efficiency. This is because each leg of supply/ return piped water loses its heat during the off-cycle despite being insulated. The cylinder should be located within 9 metres of the Econergy® water heater for retrofit installations and directly adjacent for new installations.

## WETBACK SYSTEMS



**The Econergy® system cannot be used with a wetback system where the piping design allows a thermosyphon to develop**

Wetback systems involve large bore copper pipes running into the cylinder and back again. Because the heat source is uncontrolled, temperatures can rise to 100°C, generating steam. Plumbing codes dictate that an open vent is used to eliminate the possibility of an explosion occurring due to rapid pressure rise in the system.

Econergy® units can be combined with wetback systems but only with strict constraints as the temperature limit on the Econergy® water heater is 80°C. The Econergy® water heater unit must be mounted level with the hot water cylinder or below, and the piping designed to eliminate a thermosyphon loop to stop the possibility of over temperature hot water circulating from the cylinder to the unit.

# SOLAR WATER HEATING SYSTEMS



**The Econergy® system cannot be used with a solar water heating system where the piping design allows a thermosyphon loop to develop**

Solar water heating systems, like wetback systems, are usually uncontrolled systems. Temperatures can rise to 100°C, boiling the water. As the Econergy® system is super-efficient it would not normally be required to integrate the unit with a solar water heating system, however if this was specified or required by the customer then the piping design (as per wetback) must be designed to avoid thermo-syphoning of high temperature water through the unit while not running.

## RING MAIN MANAGEMENT (OPTIONAL)

A ring main should not be used on an Econergy cylinder setup without management unless it is operated from a separate cylinder. Ring main management is a software update that can be installed during production. A switch or PIR sensor(s) can be wired to the heat pump and the heat pump will control the ring main circulation pump (ring main pumps are not supplied as part of a typical Econergy system unless specifically requested). Once the mechanism is triggered, the ring main pump will be activated for 60 seconds to flood the ring main with hot water. A minimal amount of hot water may be reintroduced back to the cylinder as a result. The ring main pump will then be locked out for 30 minutes regardless of additional triggers.

# HOT WATER CYLINDERS

The Econergy® water heater requires a well-insulated hot water cylinder to function correctly. The tank must be sized to the maximum anticipated draw off in an 8-hour period so that the consumer does not run out of hot water. As a guide, we recommend 300L for a family of 4. The water heater unit can be retrofitted to any electric cylinder as long as it has PU or EPS insulation. Econergy® water heaters cannot be installed into gas HWC's as they are generally inefficient and there is no electrical backup .

## Econergy Heat Pump Ready HWC—Recommended Storage Sizes

Household Size #Adults	Recommended Size	Ordering Code
2	180L	EC180L
3	250L	EC250L
4 – 6	300L	EC300L
6+ / High Use	350L+	EC [capacity] L Custom



The Econergy cannot be retrofitted to gas hot water cylinders, or any storage tank that cannot deliver more than 50kPa pressure to the pump inlet.

## A) New Construction





We recommend Econergy® heat pump ready hot water cylinders. Available in mains pressure stainless steel, these contain dual 20 mm inlet fittings, dedicated 20 mm return fittings and dual sensors integrated into the tank. They are guaranteed from the factory with a 10-year warranty. Use of Econergy® heat pump ready cylinders avoids any potential warranty issues resulting from modification to fit sensor pockets.

## B) Retrofit

Retrofit can be made to any electric hot water cylinder with PU or EPS in good condition by teeing into the cold-water line just before the tank isolation valve and by fitting a tank outlet fitting (code HPTP) into the hot water outlet line. It is recommended not to fit a pressure relief valve to an old LP cylinder as this could cause leaks.

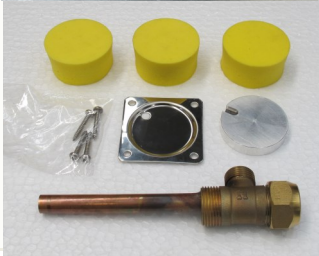

# ORDERING ECONERGY ACCESSORIES

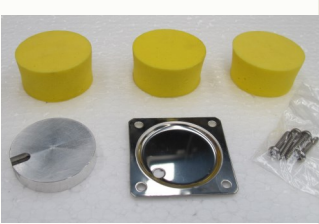
Part No.	Application	Picture
Tank Pocket <b>HPTP</b>	Tank Pocket - For retrofit to Rheem Stainless Solar Ready HWC	
Condensate Fitting <b>PF0128-B</b>	For outdoor installations requiring a condensate drain	
Generic Retrofit Kit <b>HPGRK</b>	For retrofit to existing hot water cylinders	
Coopers Solar Ready Retrofit Kit <b>HPCRK</b>	For retrofit to Coopers Solar Ready Hot Water Cylinders	
Dux/Rinnai Retrofit Kit <b>HPTSK</b>	For retrofit to Dux Proflow and Rinnai Hotflow Hot Water Cylinders (aka Tank Sensor)	

This page is intentionally left blank

# INSTALLATION

## Standard Specifications

No.	Installation Component	Approved Specification
	<b>Plumbing Installation</b>	
1	Piping systems from Heat Pump Unit to Hot Water Cylinder	15mm nominal bore piping (no more, no less). Dux or Buteline Polybutylene REHAU PE Kembla PEX Fusiotherm Copper AS/NZS compliant
2	Pipe Line Fittings	Dux Secura, REHAU, Fusiotherm, Kembla PEX or AS/NZS Standard DR brass fittings
3	Flexible Hoses	<b>NOT ALLOWED</b>
4	Ball Valves	Use only full flow 15mm tee handle valves. Bugatti, PWL, Econergy
5	Pipe Insulation	Min 13mm wall Armaflex or approved equivalent. All piping to be fully lagged along its length
6	Max Pipe Distance	9 m flow 9 m return

No.	Installation Component	Approved Specification
	<b>Electrical Installation</b>	
1	Low Voltage Cable	CAT5 UTP, 24AWG and rated to 1 amp max
2	Main Cable	2.5 TPS, 2 x 2.5mm <sup>2</sup> + E, compliant to AS/NZS5000.2
3	MCB	To suit electric back element rating. Max permissible 20A



# INSTALLATION PROCEDURES



**Adequate access and space for service must be allowed for all types of installation**

## Mounting System

### **A) Outdoor Mounting.**

Lay the unit on its side using the cardboard packing as protection. Drill holes for mounting bolts and rubber pads. Place heat pump on rubber pads with holes aligned and bolt to the ground.

### **B) Closed Garage Installations.**

Cold air leaving the unit must be ducted to the outside without loss of air flow. A fresh air supply must also be installed to ensure that the correct air flow through the heat pump is maintained.

1. Windows are insufficient for this purpose.
2. Ensure no objects can be placed within 500 mm of the heat pump as
3. this will reduce its efficiency.
4. Allow for drainage of water naturally produced by the cooling coil (evaporator) from within the heat pump

### **C) Open Ended Garage Installations.**

The heat pump must be installed on brackets as high up to the ceiling as possible with louvers fitted to direct the cold air from the unit to fall to the floor. This allows the cold air to flow along the floor to the outside and the heat pump receives warmer air from under the ceiling which makes the unit considerably more efficient. The height at which the heat pump is installed must also allow the covers to be lifted vertically over the top of the unit for service and electrical installation.



**Do not invert the outdoor unit to attach the mounting feet or at any other time during installation. This may cause damage to internal components and may void the warranty**



**Do not wall mount the unit on any timber framed wall (with or without brick veneer)**

**Please Note:** If the heat pump is installed in a coastal situation, efforts should be made to protect the unit from salt spray to avoid premature corrosion.

### Pre-Wiring & Pre-Plumbing for Renovations & New Builds

This is required if piping and/or cables need to run through walls/floors/roof cavities etc. Run 1x Mains cable and 1x CAT-5 UTP cable allowing an extra 2m free play at either end. Run 2x 15mm pipes, fully insulated along their length.



**A pre-made CAT- 5/6 cable is required for installation of Econergy heat pumps**

# PIPING DIAGRAMS

**Figure 3: Retrofit to Generic Single Inlet Hot Water Cylinder (eg Rheem NZ)**

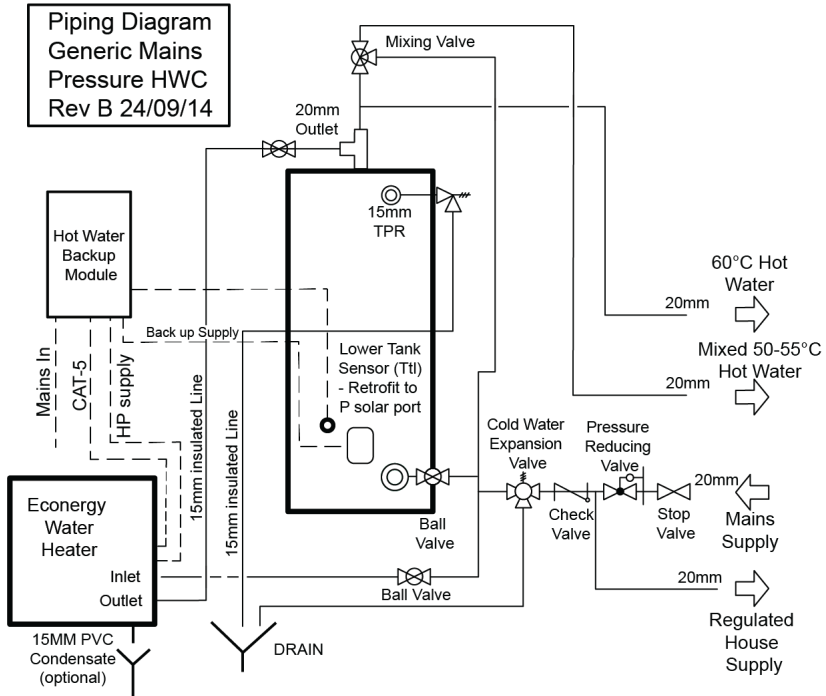

## Econergy Accessories Required

No	Part Number	Description	Purpose
1	HPGRK	Generic Retrofit Kit (comprises tank fitting and tank sensor kit).	Allows retrofit to any standard hot water cylinder

1. Cylinder must be post 1988 and in good condition
2. Fitting of Tank Sensor kit (HPTSK) may void HWC's manufacturer warranty
3. Ensure minimum pressure of 50kPa met on low pressure installations (may require fitting of relief valve to open vent HWC)



**Figure 4: Retrofit to Coopers Ready Mains Pressure Hot Water Cylinder**

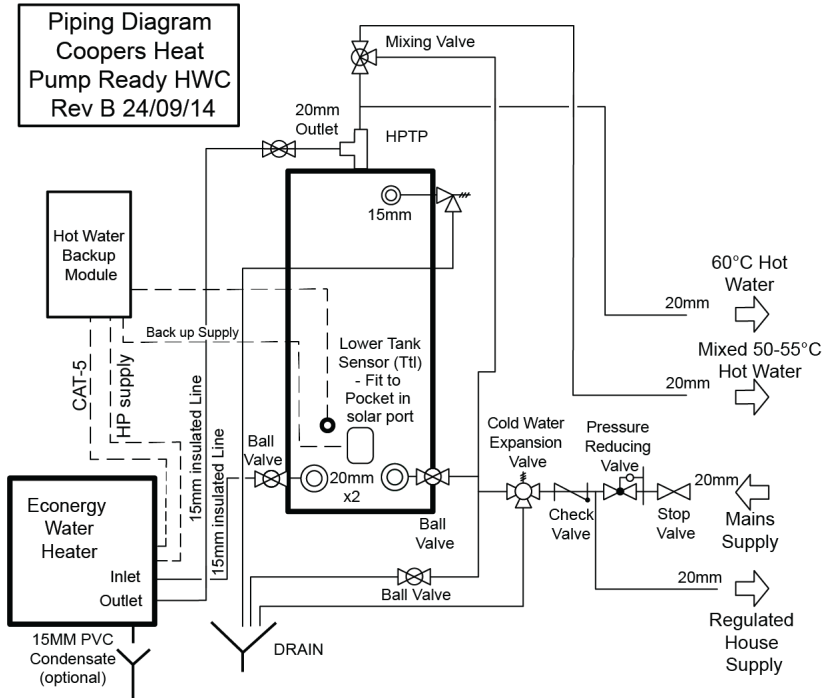

**Econergy Accessories Required**

No	Part Number	Description	Purpose
1	HPCRK	Coopers (Solar Ready) Retrofit Kit	Comprises HPTF Tank Fitting and HPTP Tank Pocket

1. DO NOT connect return line to heat pump to solar connection!
2. Ensure minimum pressure of 50kPa met on low pressure installations (may require fitting of relief valve to open vent HWC)

**Figure 5: Connection to Econergy® Heat Pump Ready Hot Water Cylinder**

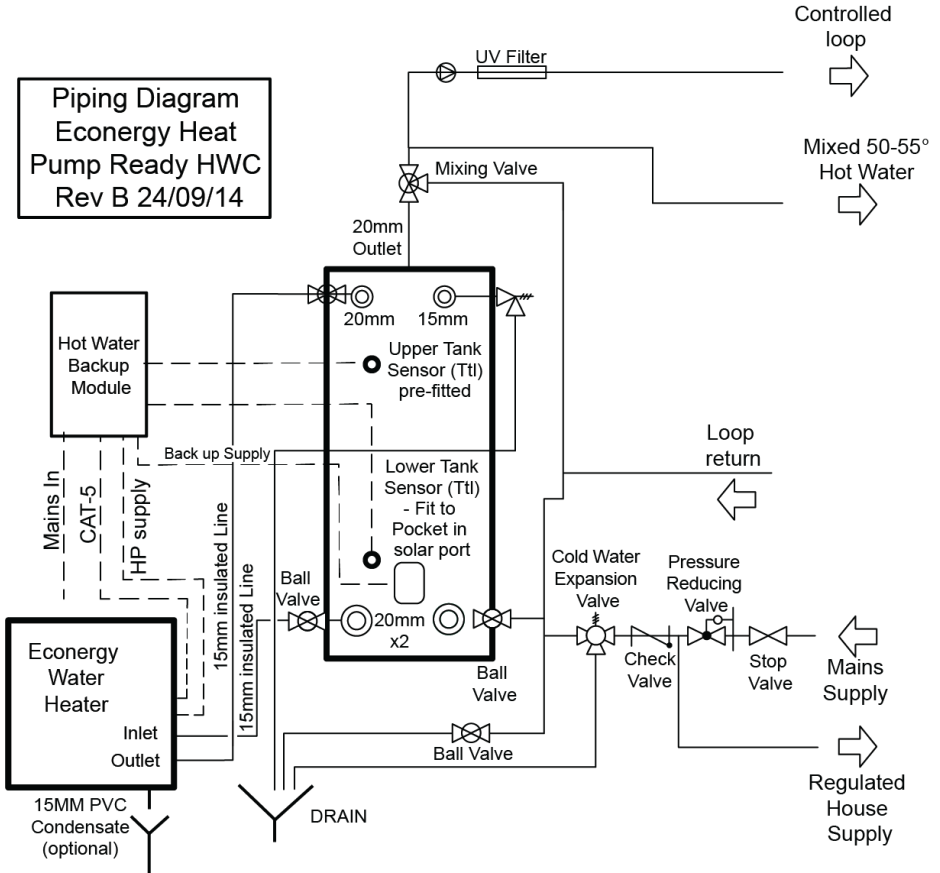

**No Econergy Accessories Required**

1. TPR valve is provided in element cover.

# PIPING INSTRUCTIONS

## 1. Plumb Water Heater to Hot Water Cylinder

Plumb the water heater unit in accordance with the correct piping diagram to match the type of cylinder being connected to. Ensure inlet (blue) of heat pump is connected to bottom of HWC and outlet (red) of water heater is plumbed to top of the HWC. All plumbing to be carried out in accordance with AS/NZS 3500 and NZ BC Section G12

## 2. Mount Hot Water Backup Run Electrical Cables

The hot water backup module (HWB) shall be mounted close to the hot water cylinder in a location that is easily visible to the hot water user. All wiring to be completed according to AS/NZS3000 and Field Wiring Diagram in page 23 of this manual. Fit isolators next to HWC and within 1 metre of the water heater unit in an easily accessible location. Run all cables from heat pump unit through conduit or trunking to the hot water cylinder location.

## 3. Tank Sensor Mounting

- a) **Econergy Hot Water Cylinder.** This comes with dual sensors, upper and lower. Insert the lower tank sensor into the pocket about 1/3 of the way up the HWC and secure with adhesive or silicone sealant. Take both sensors and plug them in to their respective locations in the hot water backup (HWB) module TTu/Ttl
- b) **Coopers or Rheem Solar Ready Hot Water cylinder.** The plumbing installer needs to thread a tank pocket into the solar port of the hot water cylinder and ensure there are no leaks. Apply thermal paste to the tank sensor and insert the tank sensor into the pocket. Secure the tank sensor with building adhesive or silicone sealant. Plug the tank sensor into the header marked J4 or Ttl on the circuit board of the HWB module
- c) **Generic Hot Water Cylinder.** Drill a 51mm (1/2") diameter hole in the hot water cylinder jacket at a height ¼ (25%) of the way up the cylinder, when measured from the bottom.

Apply thermal paste to the tank sensor. Push tank sensor through the tank sensor cover and lodge it in the tank sensor mount.

Apply 9cc of thermal paste (supplied with Tank Sensor) to the back of the tank sensor mount and place it in the drilled hole against the inside layer of the cylinder.

Adjust the foam core supplied such that when inserted with the pocket into the hole it sticks out by at least 10mm. Insert the tank sensor foam core, and then attach the tank sensor cover using the screws provided. Pilot holes of 3.2mm (1/8") diameter will need to be drilled for these screws. Plug the tank sensor into the header marked J4 or Ttl on 1 the circuit board of the HWB module.



**Do not wall mount the unit on any timber framed wall (with or without brick veneer)**

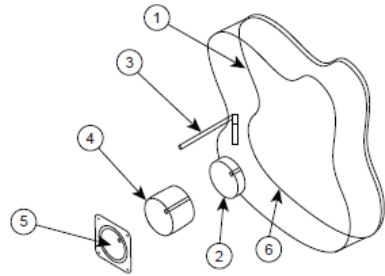
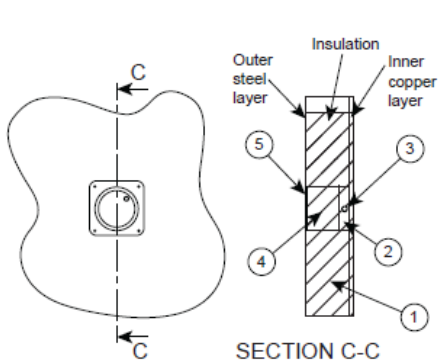

Item No.	Description	Part No.	Quantity
1	Hot Water Cylinder Wall	HPX-831	1
2	Tank Sensor Pocket	HPX-811	1
3	6m Sensor		1
4	Sylomer Insulating Core	HPX-832	1
5	Tank Sensor Cover	HPX-821	1
6	Thermal Paste		200ml

#### 4. Electrical Connections

All electrical connections must be made, by a licensed tradesman, according to the diagram below. The appliance must be installed in accordance with AS/NZS 3000:2000. A means for disconnection must be incorporated in the fixed wiring. A Certificate of Compliance must be issued by the installer.

#### 5. Condensate drain

Condensate drains must be run where the unit is discharging on a concrete path or other location where wetness/mould is not desirable.

Use PF0128-B accessory. Mount the fitting into the punched hole at the bottom left rear of the water heater unit. Run hosepipe to the nearest drain location.



**Only Econergy® factory sensor cables provided with the unit shall be installed. Use of substitute sensor cables or splicing cables may void warranty.**

# COMMISSIONING

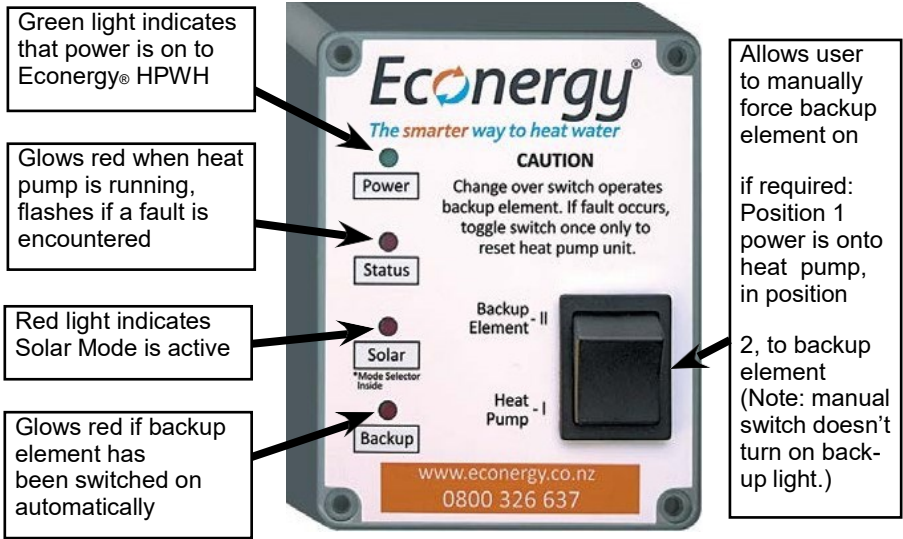

- Fill system with water and leak test all connections at system pressure.
- Check all electrical connections and ensure that water heater is securely grounded to the building's earthing point.
- Ensure both isolation valves on supply and return lines are open.
- Loosen fitting on inlet water heater to heat pump until water flows from fitting. Close fitting.
- Connect laptop to RS232 extension cable on machine and open Econergy® Config Software (if installer has a copy of the software).
- Switch on Main Isolator and Heat Pump Isolator.
- The green (power) light should be lit on the Hot Water Backup Box located on the hot water cylinder.



**NOTE:** If the heat pump is connected to an off-peak power supply or 'ripple control', power may not be available at certain times of the day. We recommend temporarily running a mains supply to the main isolator to allow testing of the heat pump water heater in this case.

- After an 8-minute delay unit will start. The status light will glow solid red.
- The unit will preheat the water to 60°C which takes 3-5 minutes, then the hot water outlet connection will be hot to the touch.
- (If available). Check that the unit has reached 60°C on the Econergy® installation software and the flow has stabilized.
- The unit will now heat the whole tank from the top down until the return temperature is 50°C.
- Tidy up installation.
- If there is time then check that the whole tank has heated successfully otherwise check back later and use the Econergy® Config software to download the events log to ensure that the unit is operating as expected

# TROUBLESHOOTING

If the Econergy® water heating system is not working correctly as per the commissioning instructions above, please refer to the following troubleshooting information.

Symptom	Possible Cause	Things to Check
Unit is not heating	a) Isolation valves are closed	Check valves in supply and return lines from water heater to HWC and open if closed.
	b) Airlock in system	Close isolation valve going from water heater unit into top of HWC. Slacken fitting on outlet of water heater and purge for a minute or so. Close fitting, open valve and restart unit.
	c) heat pump has lost refrigerant charge in transit	Check 8mm pipe coming out of top of compressor. After 5 minutes running it should be hot to touch. If not, the unit may have lost refrigerant.  Call 0800 32 66 37 for service support
No hot water, status indicator has lights off	a) No power to hot water cylinder	Check all switches are on, there is power to house and circuit breaker marked "hot water" is ON
	b) Ripple control activated	Either a) temporarily bridge out relay in board OR b) run temporary feed to heat pump to allow commissioning to occur.

Symptom	Possible Cause	Things to Check
Water temperature too low	a) temperature valve set incorrectly or malfunctioning	Remove cap from top of tempering valve and screw in to increase water temperature.
	b) partial loss of refrigerant or other sealed system malfunction	Call 0800 32 66 37 for service support.
Unit stops running less than 30 secs of operation	a) Indicates fault with thermistors or thermistor inputs on PCB or damaged CAT-5 cable.	Remove HWB panel and cover on main electrical box. Check that all sensors are plugged into their correct locations and the CAT-5 cable is securely plugged in and undamaged. If unit still stops use Config Software to determine which thermistor is out of spec and rectify accordingly.
Unit stops Running after 10-15 mins operation	a) Likely indicates unit has cut out on high condenser temp event	Check that ball valves are open. Close isolation valve going from water heater unit into top of HWC. Slacken fitting on outlet of water heater and purge for a minute or so. Close fitting, open valve and restart unit. If this fails, use Config Software to determine what is causing the unit to stop. Call 0800 32 66 37 for service support.



Symptom	Possible Cause	Things to Check
Unit faults after heating entire tank	a) Likely tank sensor mounting issue	Ensure tank sensor is securely mounted in place. Rectify if required and retest.
Water is dripping from rear of unit (behind finned evaporator)	a) This is normal as the unit will remove moisture in the air above 70% RH	No action required.

**Note: If you suspect a serious fault or if the issue persists, please contact HWHP at 0800 33 66 33 for servicing.**

# IMPORTANT INFORMATION

- This product has a classification of 6.101 for appliances not accessible to the general public.
- The appliance is not intended for use by young children or infirm persons without supervision.
- Young children shall be supervised to ensure they do not play with the appliance.
- If the supply cord is damaged, it must be replaced by the manufacturer or its service agent.
- The fuse on the electronic controller is 6A/250V. This should only be replaced by a qualified electrical service technician or electrician.

# FIELD WIRING DIAGRAM

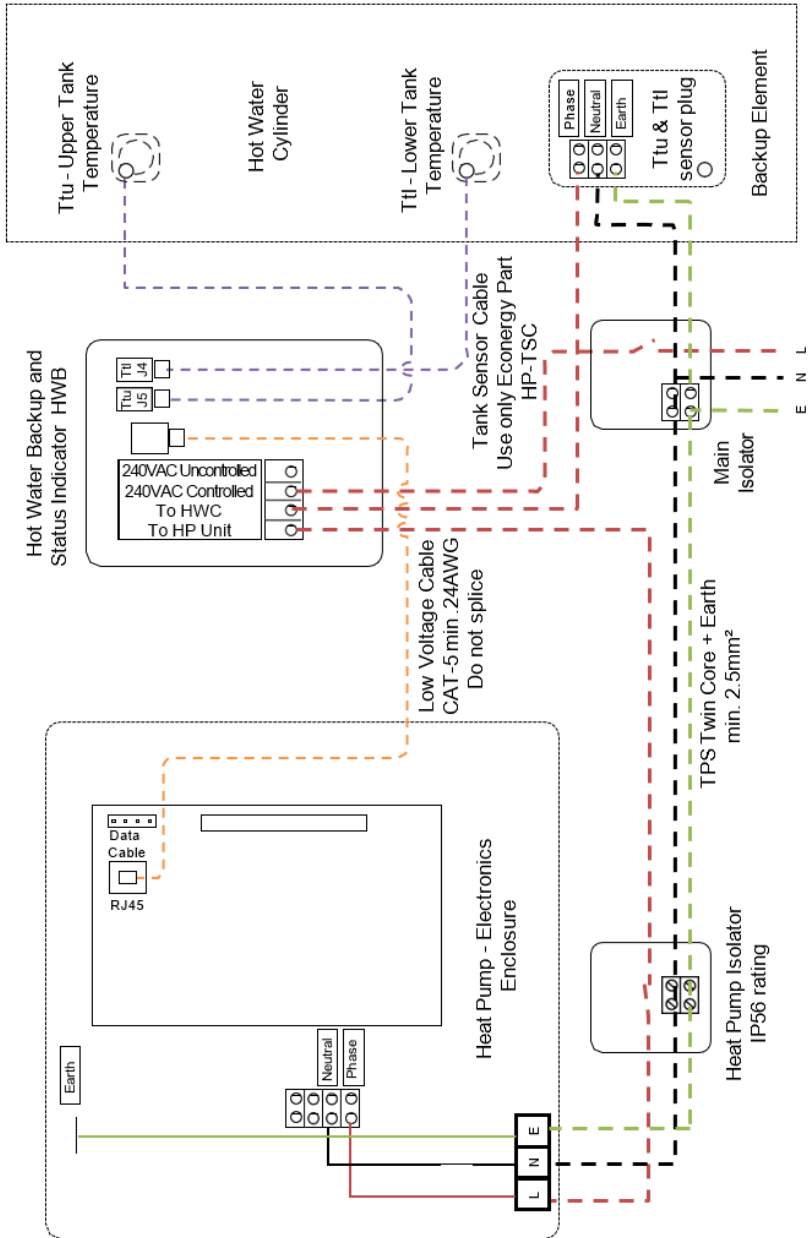

# TYPICAL HEAT PUMP READY WATER CYLINDER PRODUCT SPECIFICATIONS

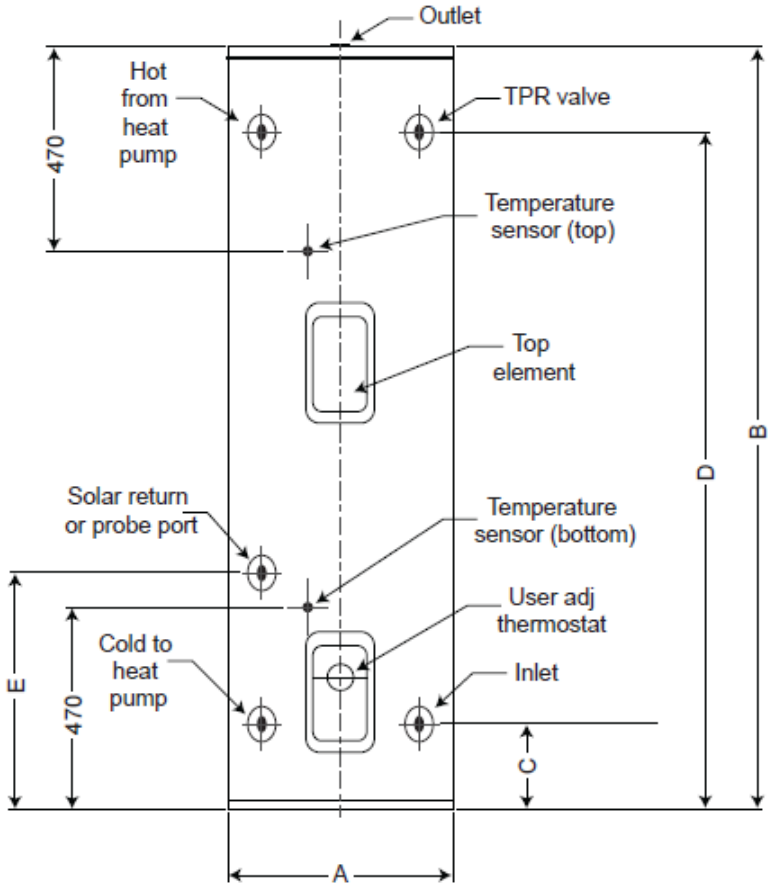

Do not scale. If in doubt, ask

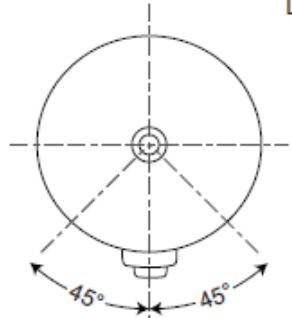

## TECHNICAL DATA TABLE DIRECT CYLINDERS - ECONERGY

Model Number	EC180L	EC250L	EC300L	
<b>Total storage capacity</b>	181 L	252 L	295.5 L	
<b>Storage capacity above topelement</b>	85 L	136 L	160 L	
<b>Storage capacity at 470mm from Cylinder Jacket Top (Temperature Sensor)</b>	43 L	60 L	60 L	
<b>Storage capacity at 470mm from Cylinder Jacket Bottom (Temperature Sensor)</b>	44 L	59 L	59 L	
<b>Weight Empty</b>	37.5 kg	51.5 kg	61 kg	
<b>Inlet / Outlet Connections</b>		RP 3/4" / 20		
<b>Solar / HP Feed Connection</b>		RP 3/4" / 20		
<b>Solar / HP Return Connection</b>		RP 3/4" / 20		
<b>T&amp;PR Valve Connection</b>		RP 1/2" / 15		
<b>T&amp;PR Valve Setting</b>	1000 KPa	1000 KPa	1000 KPa	
<b>Dimensions</b>	A	488 mm	580 mm	580 mm
	B	1770 mm	1596 mm	1846 mm
	C	200 mm	165 mm	165 mm
	D	1575 mm	1418 mm	1668 mm
	E	550 mm	565 mm	565 mm
<b>Element Rating (Factory Fitted)</b>	2.0 kW	2.0 kW	2.0 kW	
<b>Top Element Rating (Kitset)</b>	2.0 kW	3.0 kW	3.0 kW	

# ECONERGY® HP SERIES WATER HEATER SPECIFICATIONS

<b>General</b>	<b>THD3500</b>
Height	590 mm
Width	750 mm
Depth	300 mm
Weight	48 kg
Noise rating @ 1.5m	52 dBA
Circuit Breaker	16 amps
Rated Current RLA	4.4 amps
Refrigerant	R-134a
Refrigerant quantity	520 gm
Ambient Air Temperature	-5 to 40°C

<b>Performance Specifications **</b>	<b>THD3500</b>
Heat output	3000 W
Rated input	930 W
Recovery rate	57 L/hr
Efficiency (COP)	3.22 W/W

<b>Water / Connections</b>	<b>THD3500</b>
Min Supply Pressure	50 kPa
Max Supply Pressure	800 kPa
Min/Max Inlet Water Temperature	5 - 50°C
Flow/Return Connections	RP1/2" / 15mm
Condensate Drain	15 mm
Max Total Dissolved Solids	250 mg/L
Max saturation index -	+0.80

\*\*Rated at Conditions (25°C / 15°C / 60°C /70%) (Cold water/ Ambient Air/ Hot Water/70%RH )

## COMPANY INFORMATION

Hot Water Heat Pumps LTD.

0800 33 66 33 | 09 838 9444

[info@waterheating.co.nz](mailto:info@waterheating.co.nz) | [www.waterheating.co.nz](http://www.waterheating.co.nz)

PO Box 21 586, Henderson, Auckland 0650



**HOT WATER HEAT PUMPS LTD**

Advancing Water Heat Pump Technology

**SINCE 1980**

**NOTES:**

---